

Product lineup



Features

- High rigidity achieved by the use of zinc alloy
- Higher torque with horizontal use dampers (Up to 8.8 N·m)
- Superior damping responsiveness

Product name	Torque [N·m] (lbf·in)	Damping direction
TD42A2-50K	4.90 (43.37)	CW
TD42A2-70K	6.86 (60.72)	
TD42A2-90K	8.83 (78.15)	

Product name	Torque [N·m] (lbf·in)	Damping direction
TD42B2-50K	4.90 (43.37)	CCW
TD42B2-70K	6.86 (60.72)	
TD42B2-90K	8.83 (78.15)	

Product specifications

Durability

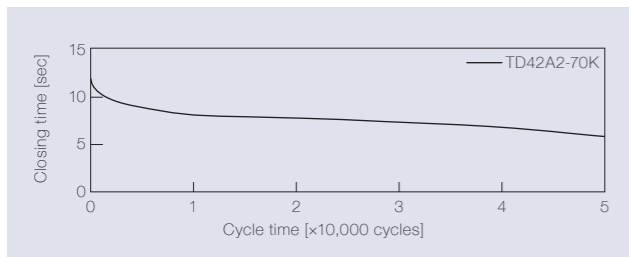

Torque	6.86 N·m (60.72 lbf·in)	
Radial load	N/A	
Angle range of closing time	60 to -30 deg.	
Temperature	23 ± 2°C (73.4 ± 35.6°F)	
Durability	Excluding TD42A2/B2-90K	50,000 cycles
	TD42A2/B2-90K	30,000 cycles

Temperature characteristics

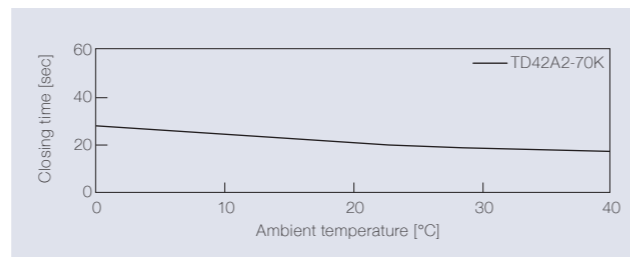

Measured according to the performance management testing method shown below after leaving in each designated ambient temperature for over one hour.

Performance management testing method

As the torque of partial rotation angle dampers is not consistent, the closing time measurement jig is used for the performance tests.

[Operation during measurement]

(Secures the housing of a rotary damper and moves its shaft)
All rotary dampers are managed by the following closing time test.

Test mode [90° → 60° (Pause) → (Free fall with damping) → -30°]
* Horizontal plane: 0°

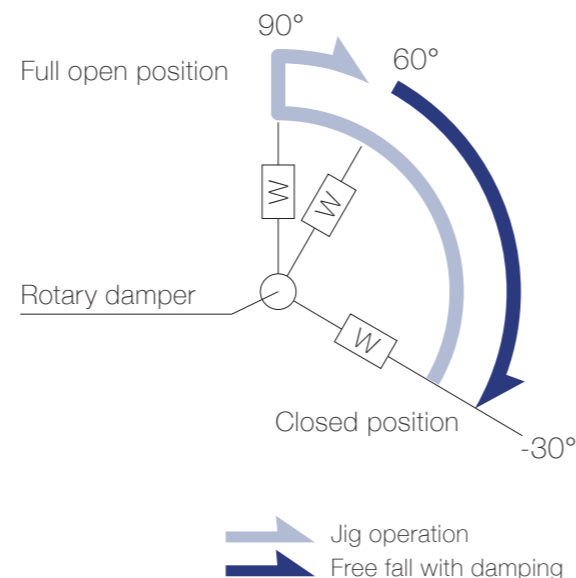

Inspection specification before shipping

Type	Preset torque [N·m] (lbf·in)	Closing time
50K	4.90 (43.37)	5 to 25 sec
70K	6.86 (60.72)	
90K	8.83 (78.15)	

Product information

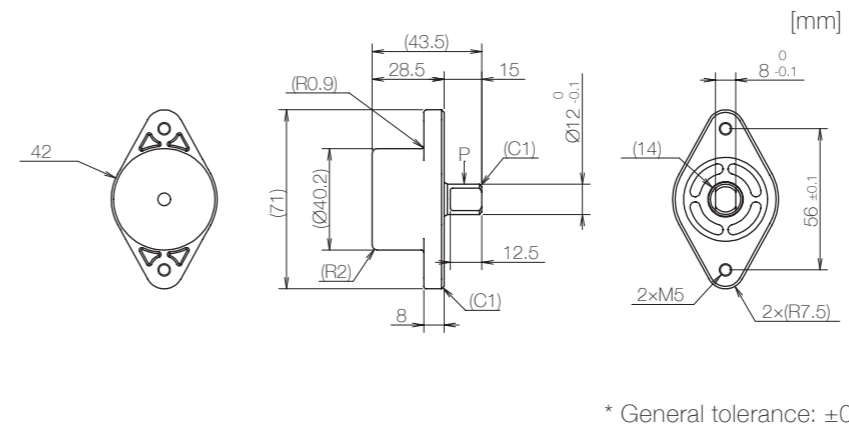

* General tolerance: ±0.2

- Opening angle: 120°
- Product weight: Approx. 220 g
- Allowable radial load (P): 9.8 N

Main materials

Housing	Zinc alloy (ZDC)
Ring screw	Zinc alloy (ZDC)
Shaft	Zinc alloy (ZDC)

Dimensions related to mounting

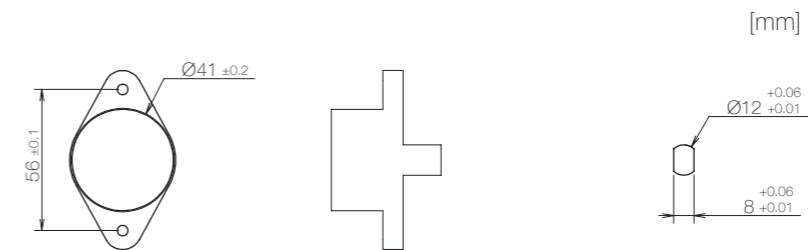

Opening angle

TD42A

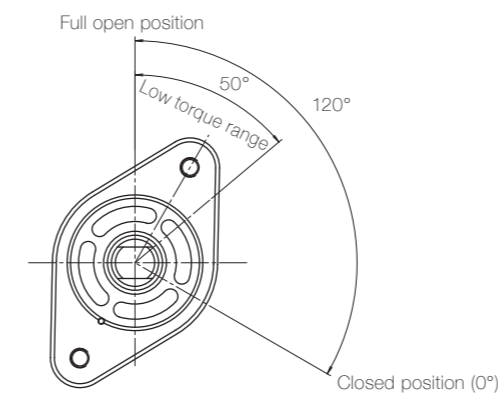

TD42B

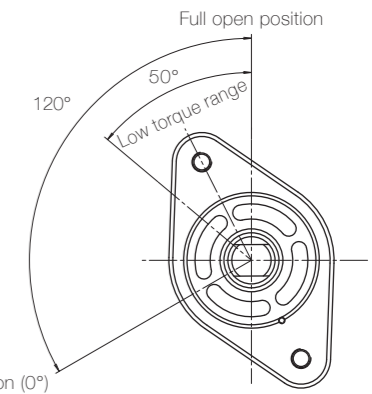

* Shaft position at the time of shipping: Closed position

Damping directions

Rotation directions of the shaft to which torque is applied

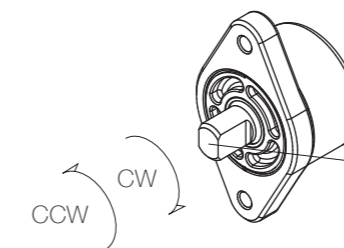

* Housing secured / Shaft rotatable

Damping direction	Engraved mark
CW	CW
CCW	CCW